



STEP 552™

– for door environments with high-security requirements and door automation

This motor lock can provide high-rated burglary protection in combination with door automation, fire safety and evacuation requirements. Designed for high-frequency door environments.

STEP 552 is one of the most secure motor locks on the market. The lock case is made of stainless steel and has a modern bolt placement with the hook bolt located in the center of the lock case. The unique automatic latch bolt enables opening with door automation.

Suitable for security class 1, 2, 3 acc. to SSF 200, and class 5, acc. to SSF 3522, as well as Grade 7 acc. to EN 14846:2008. It can be included as a locking mechanism in many well-reputed security door fittings for class RC3 and RC4.

The control unit ST500C uses encrypted communication AES-128 for locking, unlocking and status indications. It can handle up to two motor locks which can be controlled individually or synchronized.

Evacuation and re-entry and fire safety requirements

STEP 552 also serves as an evacuation lock in SSF 3522 class 2B when used with STEP Exit emergency exit devices. Certified according to EN 179:2008.

Certified in fire resistance class E/EI120 according to EN 14846:2008.

Built-in technologies provide great benefits

- When the door opens electrically, the **automatic latch bolt** can fold which enables the door to be opened with door automation. Directly after the door is opened, the automatic latch bolt extends out and anchors itself in its original position, functioning again as a classic latch bolt.
- The **FreeDrive® technology** enables the locks motor and gearbox to disengages every time the door unlocks mechanically.
- The lock also has a **double blocking**, where the blocking of the hook bolt also is blocked by a latch.

When it has to work.

FreeDrive®

STEP 552

Technical data

Functional description

- The hook bolt locks/unlocks electrically via opening signal from access control system, code lock, push button or similar. The automatic latch bolt locks/unlocks electrically via an open signal from the access control system, code lock, push button or similar.
- The hook bolt lock/unlocks mechanically via cylinder follower.
- The automatic latch bolt retracts mechanically via the cylinder follower with pressure from the interior and exterior side.
- The automatic latch bolt is adapted for both right and left.

Certificates

- Certified in Class 5 according to SSF 3522.
- Certified in Grade 7 according to EN 14846.
- Certified in Grade L for corrosion, temperatures and humidity, which corresponds to high requirements according to EN 14846.
- Certified in fire technical class E/EI120 according EN 14846:2008.
- Certified for evacuation according to EN 179:2008.





Product characteristics

- Unlocks in less than 0.1 second.
- Modern bolt placement.
- Unique automatic latch bolt.
- 56 kN (5 600 kg) breaking strength.
- Panic lock function.
- Lock case in stainless steel.
- FreeDrive®.
- Manipulation-protected barrier technology.
- Back set 50 mm.
- Encrypted communication AES-128.
- Guaranteed opening, even if the door is subjected to pressure of up to 80 kg.
- Connection to the motor lock is via RS-485.
- Prepared for OSDP.
- Evacuation and re-entry are ensured with STEP Exit emergency exit devices.

Environment

- The control unit can handle temperatures from -5 to +70 degrees.
- The lock can withstand temperatures from -20 to +70 degrees.

Art.no	Description
ST552	STEP 552 Motor lock. With hook bolt and automatic latch bolt.
ST552LB	STEP 552 set with Motor lock and control unit. Incl. ST552, STEP Control unit ST500C, connection cable with adapter ST0917, drill protection ST1199, skrew and magnet set ST1192.
ST552KPL	STEP 552 complete set. Incl. ST552, STEP Control unit ST500C, STEP Lead cover ST1283, 10 m connection cable ST0916, mechanical strike plate ST9009-15, connection cable with adapter ST0917, drill protection ST1199, skrew and magnet set ST1192.

			
Fire approved: E/EI 120	Certified acc. to EN 179:2008	Factory tested: 1 700 000 cycles	Security: Grade 7 EN 14846 Class 5 SSF 3522

Combine with STEP Exit to maximize the benefits of FreeDrive®

Combine STEP 552 with STEP Exit emergency exit devices to create a secure evacuation route. Certified according to EN 179:2008.

Combine with STEP Exit to maximize the benefits of the FreeDrive®

The FreeDrive® technology disconnects the motor and gearbox, meaning that they are never affected when the exit device's lever is used. As a result, the impact on the motor and gearbox is minimized, even if the exit device is used thousands of times each day.

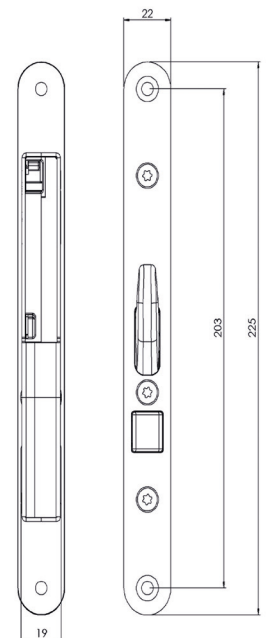
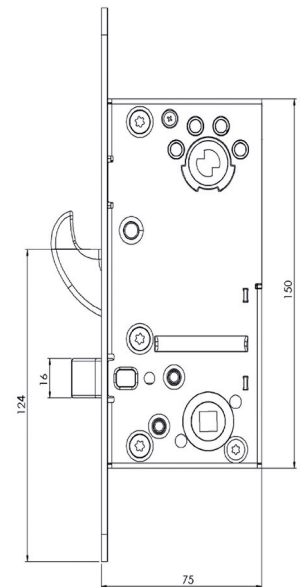

Dimensional drawing for STEP 552.



Choose from several different STEP Exit emergency devices in our Exit guide on steplock.com