



## STEP 351S™

– increases intrusion security around the clock, in high-frequency door environments

STEP 351S is a powerful motor lock with a built-in split function adapted for high-frequency door environments. Ensures high intrusion security and creates a secure locking system around the clock, without compromising on other requirements or user-friendliness. Certified in class 2A, 2B according to SSF 3522.

STEP 351S is developed for high-frequency use and can handle several million openings, just as fast as an electric strike. The lock can combine requirements for evacuation, re-entry and door automation while at the same time giving the door environment a significantly higher intrusion security and an unbeatable ease of use.

- Certified for intrusion protection according to SSF 3522 Class 2A, 2B.
- Certified for evacuation according to EN 179:2008.
- Certified in fire technical class E/EI120 according to EN 14846:2008, in combination with a latch lock.

### High ease of use with built-in split function

A built-in split function enables mechanical opening from the interior side, without the need of pushing an opening button. The lock has a by-pass function so that "Approved passage" can be obtained.

### With FreeDrive® and manipulation protected block function

STEP 351S is equipped with FreeDrive®, our patented technology that enables the locks motor and gearbox to disengages every time the door unlocks mechanically.

The lock also has a double blocking, where the blocking of the hook bolt also is blocked by a latch.

### Control units with smart features

Choose from two different control units: ST300C or ST500C, for connection to access system, alarm and central function. The control units use encrypted communication OSDP AES-128 for locking, unlocking and status indications.

*When it has to work.*



# STEP 351S

# Technical data

## Functional description

- The hook bolt locks/unlocks electrically via opening signal from access control system, code lock, push button or similar.
- The hook bolt retracts mechanically via the lever handle follower from the interior side (split function).
- Reversible mechanical split-spindle side. Changing sides is easily done mechanically on the lock housing.

## Certificates

- Certified in Class 2A and 2B according to SSF 3522.
- Certified for evacuation according to EN 179:2008.
- Certified in fire technical class E/EI120 according EN 14846:2008 in combination with a latch lock.
- Certified in Grade L for corrosion, temperatures and humidity, which corresponds to high requirements according to EN 14846.



## Product characteristics

- Unlocks in less than 0.1 second.
- Modern bolt placement.
- FreeDrive® technology.
- Manipulation-protected block function.
- Back set 50 mm.
- Encrypted communication OSDP AES-128.
- Both control units can handle re-entry.
- Evacuation and re-entry are ensured with STEP Exit emergency exit devices.
- Built in split-spindle.
- Designed to be used in high frequency doors.

## Environment

- The control unit can handle temperatures from -5 to +70 degrees.
- The lock can withstand temperatures from -20 to +70 degrees.

Art.no	Description
ST351S	STEP 351S Motor lock. Incl. ST351S, 10 m connection cable ST0916H, drill protection ST1199, magnetic contact ST0910, screw and connector set ST1192.

		
Fire approved: E/EI 120 in comb. with a latch lock	Certified acc. to: EN 179:2008	Security: Class 2A, 2B acc. to SSF 3522

## For door environments with evacuation requirements

Combine STEP 351S with STEP Exit emergency exit devices to create a secure evacuation route.

Certified according to EN 179:2008.

### Combine with STEP Exit to maximize the benefits of the FreeDrive®

The FreeDrive® technology disconnects the motor and gearbox, meaning that they are never affected when the exit device's lever is used. As a result, the impact on the motor and gearbox is minimized, even if the exit device is used thousands of times each day.

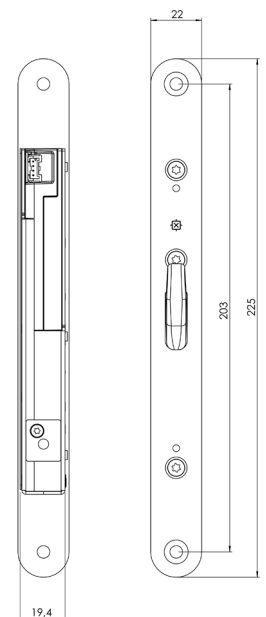
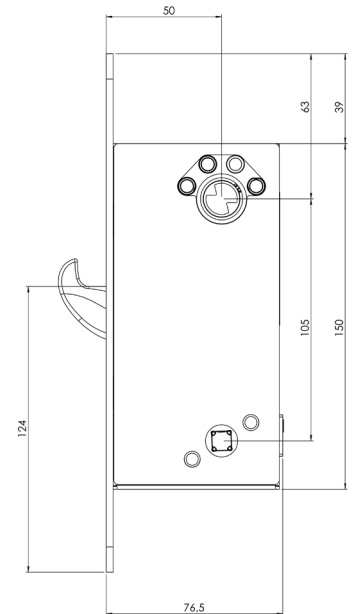

Dimensional drawing for STEP 351S.



Choose from several different STEP Exit emergency devices in our Exit guide on [steplock.com](http://steplock.com)